

PHY 1350  
Final Exam  
Fall 1993

1. A uniform ladder whose weight is 4000N rests against a smooth wall and a smooth floor, as shown. A rope is attached to the ladder at a point  $1/4$  of the way up the ladder from the base. The ladder is in equilibrium.

(a.) Draw a free body diagram of the ladder.

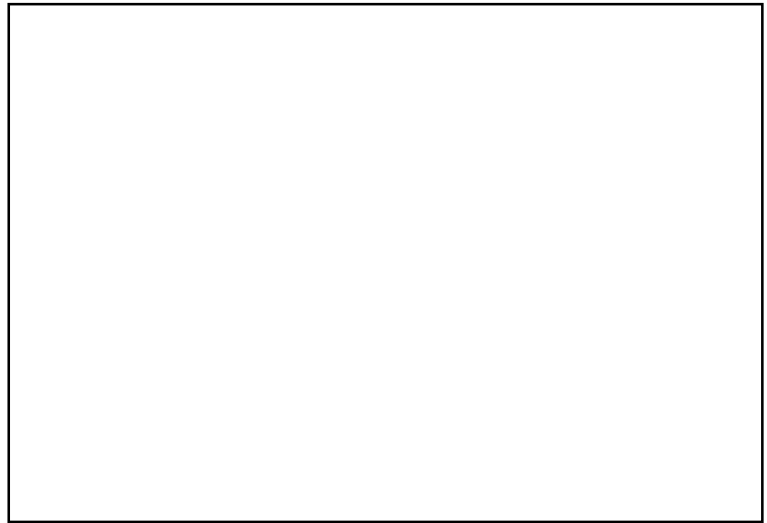
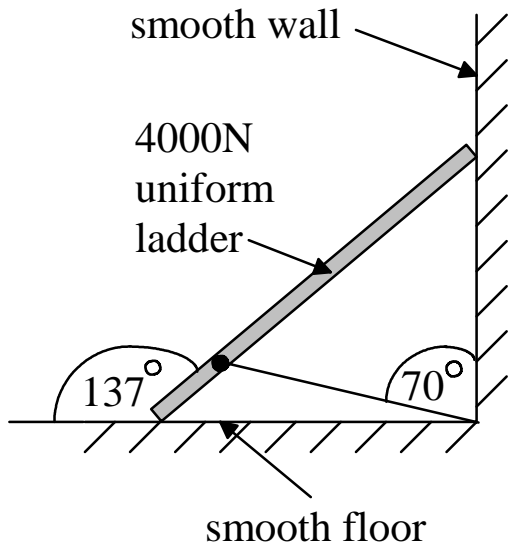

(b.) Determine the numerical value of each force acting on the ladder.

2.

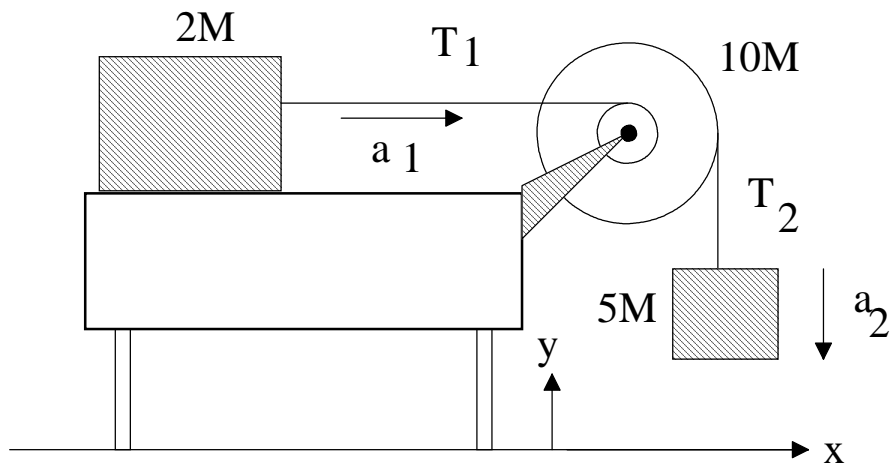

A block of mass  $2M$  is pulled along a horizontal surface by a cord whose other end is wrapped around the inner disk of a compound pulley. A second cord is wrapped around the outer disk and connects to a falling block whose mass is  $5M$ . Neither cord slips on the pulley whose inner disk has radius  $R$  and whose outer disk has radius  $3R$ . The total mass of the pulley is  $10M$  and its moment of inertia about the central axel is  $41MR^2$ . Further, the table upon which the  $2M$  block slides is rough. The coefficient of kinetic friction between the block and table is  $.500$ .

(a.) Draw a free body diagram for each of the three objects.

(b.) What is the equation relating the acceleration of one block with the acceleration of the other block?

(2c.) Write down the appropriate Newton's 2nd Law equation for each block. Also write down the torque equation for the pulley. Be careful that you define consistently the + and - direction of each quantity .

(2d.) Determine the acceleration of the falling block.

3.

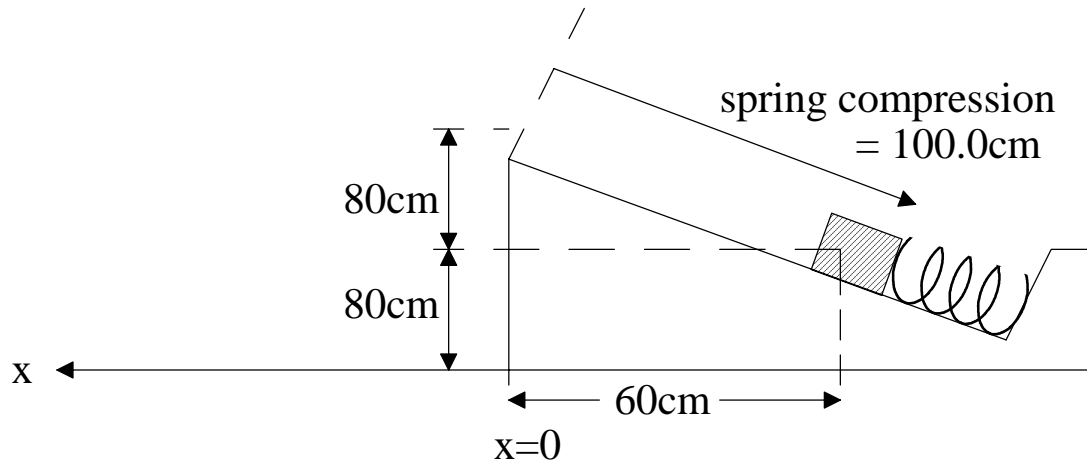

A block of mass  $3.00 \times 10^3$  grams is momentarily at rest on an incline plane which makes an angle of  $53^\circ$  with respect to the horizontal. The block is in contact with a spring whose spring constant is 800.N/m. The spring has been compressed 100.0cm. Further, a frictional force of 26.0N exists when the block slides on the plane. After the block is released, the spring causes the block to accelerate up the plane.

(a.) Using energy, determine the speed of the block as it leaves the plane.

(b.) After the block leaves the plane, it becomes airborne. Determine how far from the front edge of the plane, the block lands.  $x=?$

4. A 30.0 kg child and a 45.0 kg child are sliding directly toward each other on a horizontal, and nearly frictionless, ice rink. Each child has a speed of 2.00m/s. After colliding, the two children cling to each other and therefore move with a common speed.  
(a.) Determine the direction and speed of the pair after the collision.

(b.) How much, if any, kinetic energy has been lost in the collision?

5. A force of 10.00N at  $-25.0^\circ$  and a force of 8.00N at  $+45.0^\circ$  pull on an object whose mass is .25Kg. What is the magnitude and direction of the resulting acceleration of the object?

6.

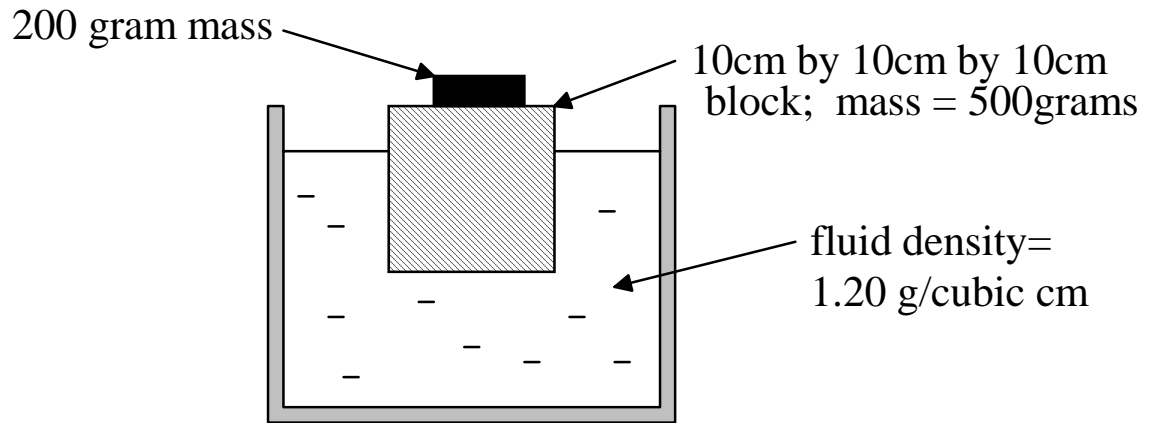

(a.) Assuming that the block is in equilibrium, what is the weight of fluid displaced by the submerged part of the block?

(b.) What is the volume of the part of the block that is out of the fluid?

7. A 0.300 Kg mass attached to a spring of force constant 30.0 N/m vibrates with simple harmonic motion. When the stretch in the spring is 10.0 cm, the speed of the mass is 30.0 cm/s. What will the speed of the mass be when the stretch is 5.00 cm?

8.

top view

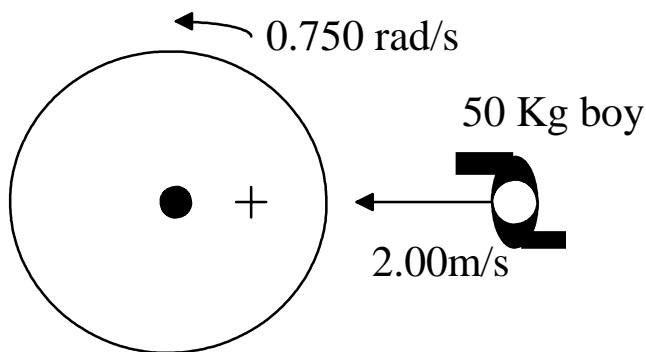

A merry-go-round has a radius of 1.60m, a mass of 500. Kg and a moment of inertia of  $640. \text{ Kg m}^2$ . The merry-go round has an initial rotation rate of .750 rad/sec before a 50.0 Kg boy hops onto it, landing at a point 0.800 m from the axel of the wheel. Before landing, the boy was headed directly toward the axel of the wheel. What is the final angular speed of the boy and wheel just after the boy has landed on the wheel?