

1.(a.) How long (in seconds) does it take the block to go from the position shown to the landing point?

1.(b.) What is the speed of the block as it takes off from the table top?

2. A 2.00 kg ball is tied inside an accelerating car as shown below. The cords are inextensible.

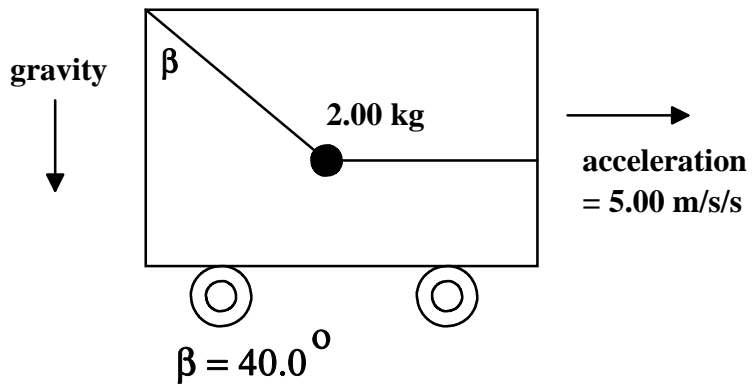

(a.) Draw a free body diagram for the 2.00 kg mass.

(b.) Determine the tension in both cords.

3. In the system shown below, three point masses are connected by a massless rigid rod, as shown. The rod is pivoted on a frictionless axel at A. Let the x-axis have origin at A and point to the right.

(a.) What is the x-coordinate of the center of mass of the rod-mass system?

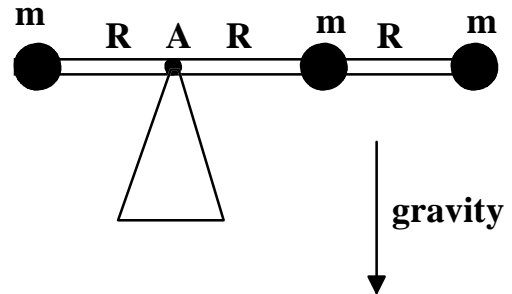

(b.) What is the moment of inertia of the system about axis A?

(c.) What is the total torque acting upon the system with respect to axis A?

(d.) Determine the angular acceleration of the system and the acceleration of the the center of mass.

(e.) What force does the pivot exert on the system at the instant shown?

4. A 50.0 kg block of wood slides Eastward with a speed of 20.0 cm/s on a smooth horizontal surface. A bullet whose mass is 2.00 grams is fired Westward and penetrates the wood, managing to exit the block on the other side with half the speed it had upon entering. Afterward, the block is found to have a final coasting speed of 19.0 cm/s.

(a.) What was the speed of the bullet before impact?

(b.) How much heat was developed during the collision?

5. The mass of a planet is 4.8×10^{25} kg and its radius is 1.25×10^7 m. What is the acceleration due to gravity at a distance of 2.4×10^7 m above the **surface** of the planet?

6. A 0.200 kg mass is attached to a spring and moves with simple harmonic motion in a horizontal plane. The stretch in the spring is given by the following formula:

$$x = .180\text{m} \cos \left(6.32 \frac{\text{rad}}{\text{sec}} t \right)$$

(a.) What is the spring constant of the spring?

(b.) What is the velocity of the mass at $t = 0.12$ seconds?

(c.) What is the total mechanical energy of the mass-spring system?

7. A uniform beam whose weight is 500.0 pounds and whose length is 10.0 feet is in static equilibrium, as shown below. Determine the tension in the cord and the friction between the base of the beam and the floor.

$$\alpha = 20^\circ$$
$$\beta = 50^\circ$$

