

1.(a.) A block of mass 1.60 kg moves to the right with a speed of 4.00 m/s on a frictionless horizontal track. It collides head on with a second block of mass 3.20 kg moving to the left with a speed of 2.50 m/s. If the blocks stick and stay together at collision, what is the final speed and direction of the combined system after collision?

(b.) How much kinetic energy has been lost from the two block system?

2. A **uniform** rod, AB, of length 5.00 m and **weight 50.0 N** is pivoted at A, (a frictionless hinge), and held in equilibrium by a rope, as shown. A load of 100. N hangs from the rod at a distance x from A. If the breaking strength of the rope is 50.0 N, find the maximum value of x .

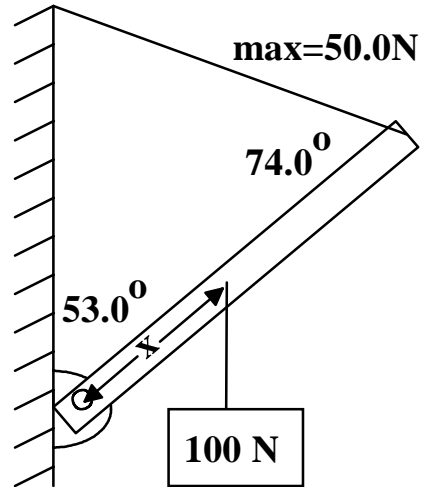

3. A uniform disk of mass 2.50m and mass 50.0kg is held in place by a frictionless axel. A light, inextensible rope is wrapped around the disk and attached to a hanging 100.0 kg mass. As the mass falls, the rope causes the disk to turn. The rope does not slip.

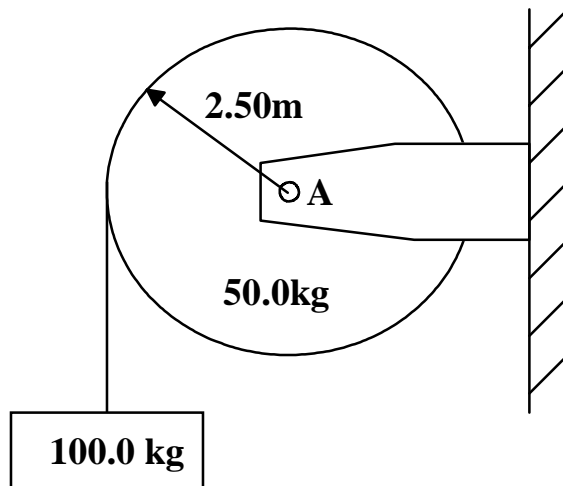

(a.) Draw a free body diagram for both the disk and the hanging block. Be sure to include ALL forces that act on each body.

(b.) Determine the acceleration of the falling mass.

(c.) Determine the tension in the rope.

(d.) How much force does the axel exert on the disk at A? What is its direction?

4. Assuming that the 100 kg mass is initially at rest, use energy concepts to determine the speed that the 100. kg mass would have after it unrolls an additional 1.50 m of rope from the disk.

5. A 5.00 kg blob of clay is thrown horizontally with a speed of 6.50 m/s at a stationary rod and cup system which is free to turn about a vertical axis, as shown. The moment of inertia of the uniform rod about an axis through its **center** and **perpendicular** to the rod is 1.00 kg m^2 . The rod is 1.00 m long and has a mass of 12.0kg. The cup is small and has a mass of 0.750 kg.

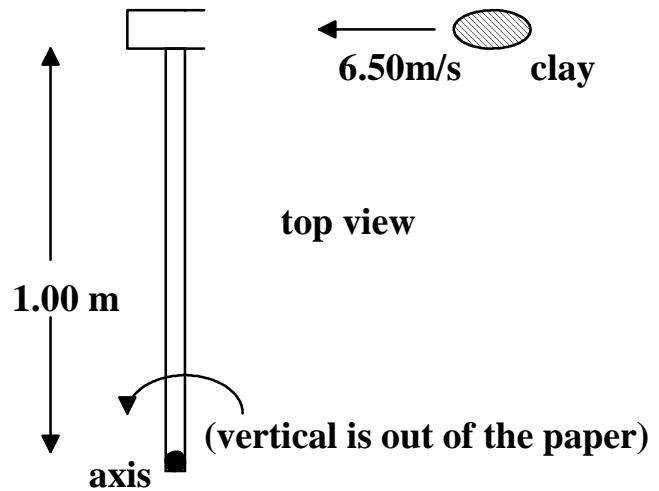

(a.) What is moment of inertia of the cup and rod system about the rotation axis which is shown out of the paper?

(b.) After the clay imbeds in the cup and sticks, what is the rotation rate of the rod-cup-clay system, assuming negligible friction in the axle.