

PHY 1350  
EXAM #2

1. A force of 50.00N at  $-130.0^\circ$  (relative to the x-axis) and a force of 18.00N at  $-40.0^\circ$  pull on an object whose mass is 0.400Kg. What is the magnitude and direction of the resulting acceleration of the object?

2. As shown below, a 200.N force pulls on a 10.0Kg object at an angle of 10.0 degrees above the horizontal. The object moves along a horizontal plane at the Earth's surface. The coefficient of kinetic friction between the surface and the block is 0.200.

(a.) Draw a free body diagram for the 10Kg block.

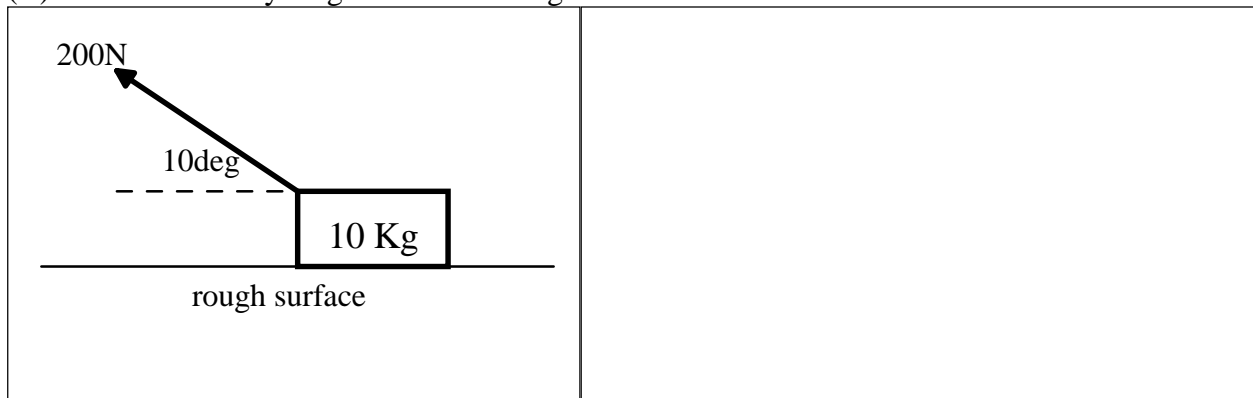

(b.) Determine the acceleration of the 10Kg block.

(3.) A 10.0Kg block rests on a smooth incline plane whose surface makes a  $30.0^\circ$  angle with respect to the horizontal. A light, flexible, non-extensible string, wrapped over a massless, frictionless pulley connects the block to a 5.00Kg block hanging over the edge of the incline.

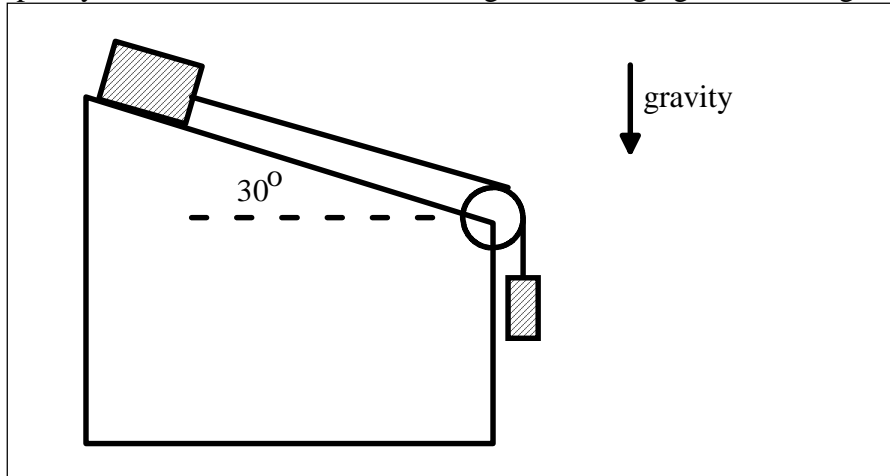

(a.) Draw a free body diagram for each mass.

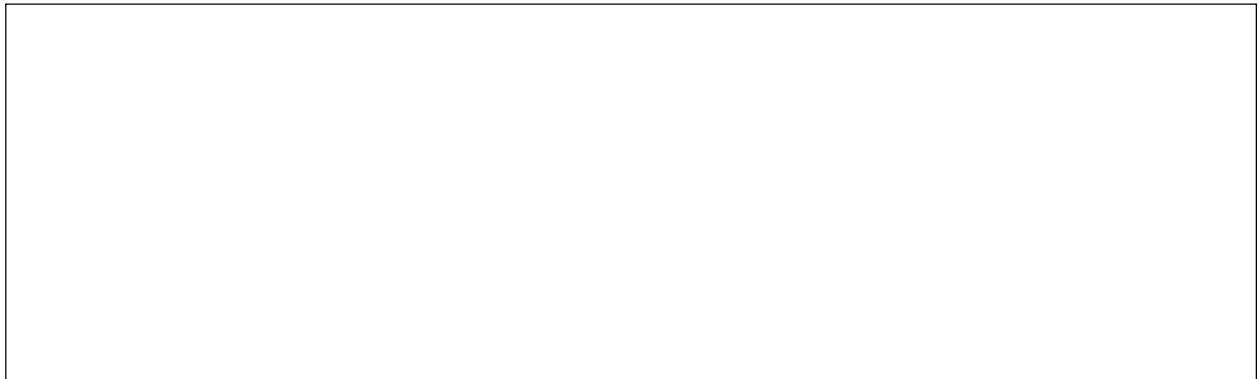

(b.) Determine the tension in the cord connecting the two blocks as they accelerate down the plane and toward the earth.

(4.) A spherical, metal bob, at the end of a 3.00m cord, orbits about a vertical pole. As the bob orbits the pole, it maintains a constant speed so that the angle between the cord and the pole remains at  $25.0^\circ$ .

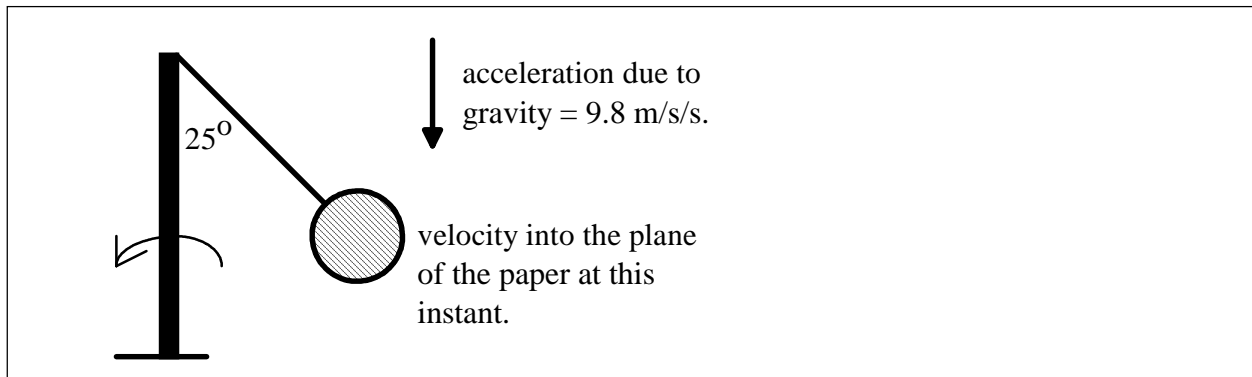

(a.) Draw a free body diagram for the bob.

(b.) What must the tangential speed of the bob be in order that the angle between cord and pole be  $25^\circ$  ?

(5.) At instant (1) shown below, a 2.00Kg mass is 0.800m above the end of a spring and is moving downward along a pole at the rate of 3.00 m/s. The spring has a spring constant of 100.N/m and has an initial compression of 0.200m. A small pin prevents the spring from uncompressing, but does not prevent the falling mass from compressing the spring further. There exists a constant frictional force of 2.50N between the pole and the mass.

(a.) Considering the block-spring-earth system, and using the coordinate system shown, what is the total energy of the system at instant (1)?

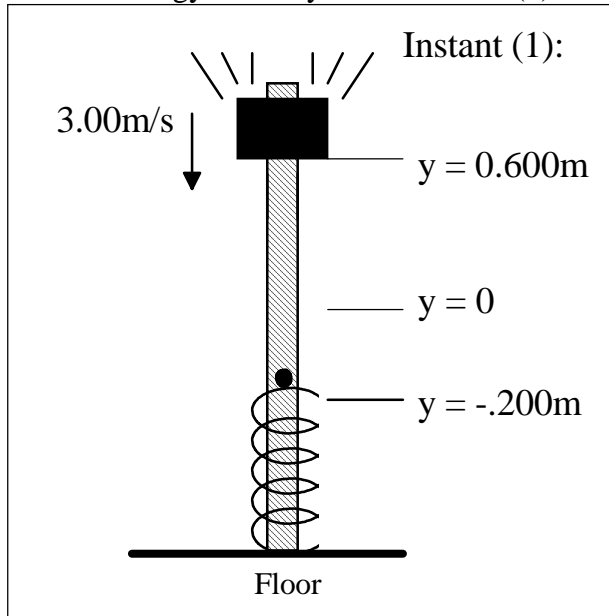

(b.) What is the maximum compression of the spring caused by the falling block?

$$dW = \vec{F} \cdot d\vec{r}$$

$$\Sigma \vec{F} = m\vec{a}$$

$$W = mgh$$

$$E = mgh$$

$$W = \left| \vec{F} \right| \left| d \right| \cos(\theta)$$

$$P = \frac{dW}{dt}$$

$$a = \frac{v^2}{R}$$

$$E = \frac{1}{2}kx^2$$

$$E = \frac{1}{2}mv^2$$

$$v_2^2 = v_1^2 + 2a(x_2 - x_1)$$

$$\vec{v}_2 = \vec{v}_1 + \vec{a} \times (t_2 - t_1)$$

$$\vec{r} = \vec{r}_0 + \vec{v}_0 (t - t_0) + \frac{1}{2} \vec{a} \times (t - t_0)^2$$

$$F = \frac{1}{2}\rho C v^2$$

$$\vec{F} = -c \vec{v}$$

$$F = \mu_K N$$

$$F \leq \mu_S N$$

$$W = \Delta E_{\text{sys}}$$